

# METEO DATA-4000 SERIES

ADVANCED MULTI-PURPOSE VERY LOW POWER DATALOGGER WITH GLOBAL CONNECTIVITY

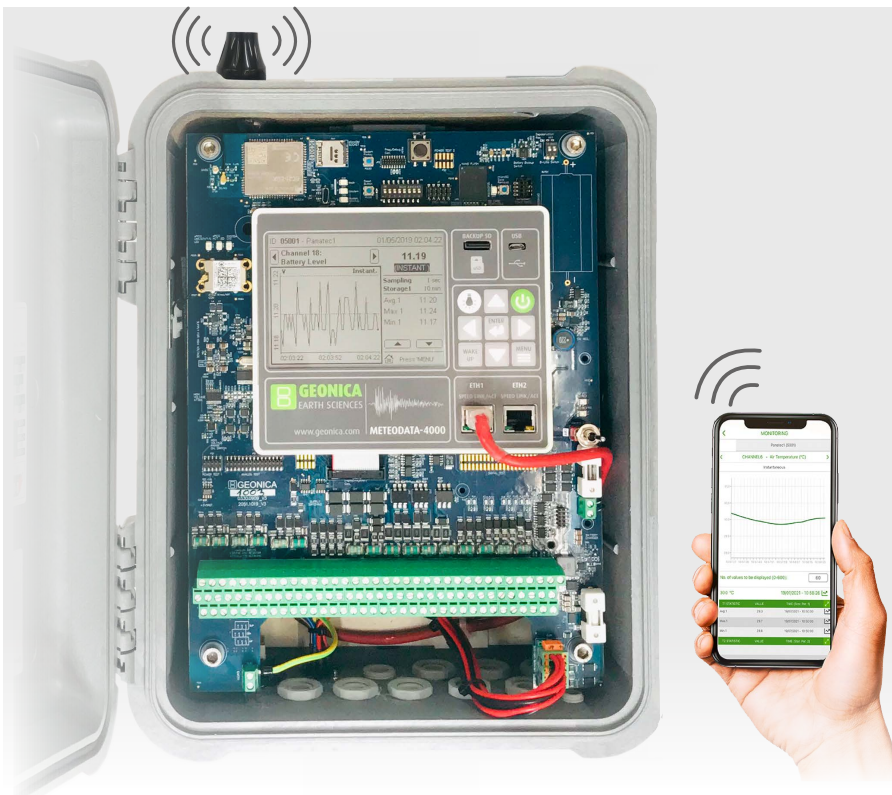

- Hydro-Meteorology
- Solar & Wind Energy
- Ports & Airports (AWOS)
- Roads (RWIS)
- Railways
- Wind & Lightning Alert
- Early Warning (EWS)
- Rain & Flood Alert
- Air Quality
- Water Quality
- Ambient Noise
- Smart Cities - IoT
- Industrial Applications

**METEO DATA-4000** Series Datalogger is an advanced 6<sup>th</sup> Generation Data Acquisition System designed and manufactured by **GEONICA**. Its versatility, reliability, robustness and very low power consumption make this unit ideal for a wide range of applications.

## METEO DATA-4016 Automatic Data Acquisition, Transmission, Teleprogrammable and Compact Unit - Configuration

### Main Features

- MTD4K Datalogger, 32 Channels
- 3 Communication Serial Buses for Smart Sensors
- 16 Single-Ended or 8 Differential Analogue Inputs or mix
- 5 Counters of 32-bit
- 4 Digital Inputs
- 4 Digital Outputs
- Ethernet Port & Modbus TCP
- 5G / 4G / 3G / GPRS / LPWAN BB & NB IoT Modem
- Wi-Fi for Local Management with **GEO-DATALINK** Mobile App, 2<sup>nd</sup> Ethernet, Satellite, Radio, etc. (select one in your order, default: Wi-Fi)
- GNSS / GPS Receiver
- Bluetooth, USB Port
- Memory: 8 / 16 / 32 GB (2-year autonomy)
- Removable micro-SD Card: 8 / 16 / 32 / 64 / 128 GB
- EMI Filtering, ESD, Surge Protections
- Dual Input Redundant Charge Controller. Up to 60 Ah batt
- 3x9 Ah Internal Batteries

### Options

- (H) HMI-4000 Graphic Memory-Display LCD QVGA 4.4" & Keyboard. Ultra-Low Power consumption
- (A) 100-240 VAC Power Supply. Note: 1 Battery less
- (CM) IP66 Enclosure (C3 paint) wiring, mounted & tested
- (C4) ISO 12944 C4 Paint for CM enclosure
- (CP) IP67 Enclosure, wiring, mounted & tested

### Optional Extension Modules

GEO-97015	6 PT100 / PT1000 (RTD) Inputs
GEO-97018 / 19	10 Inputs: Thermocouple, Voltage, Current
GEO-96018-16	16 Inputs: Thermocouple, Voltage, Current
GEO-97016	2 Strain Gauge Inputs
GEO-97052 / 53	8/16 Isolated / Non-Isolated Digital Inputs
GEO-97026	6 Analogue Inputs + 2 Analogue Outputs + 3 Digital Inputs + 3 Digital Outputs
GEO-97065	4 Isolated Digital Inputs + 5 Relay Outputs
GEO-9AD5	5 Isolated Analogue Inputs with high voltage protection
GEO-9AD8C	8 Isolated Current Inputs
GEO-NTCIP	NTCIP Protocol module
GEO-DGT	DGT Protocol module
GEO-9tGW-700	Modbus TCP to RTU / ASCII Gateway
GEO-9PDS-220	Programmable Serial-To-Fiber Device Server
GEO-94210	Industrial Proprietary LPWAN Wireless I/O
GEO-9UR32	Industrial Cellular Router Multiple Networks
GEO-9RV50X	Industrial Cellular Router LTE-A
GEO-NP	Noise Mapper Processor IEC-61672
GEO-NP	Noise Mapper Processor IEC-61672

## COMMUNICATIONS AND DATA TRANSMISSION

Four ports dedicated exclusively to simultaneous communication with applications or systems

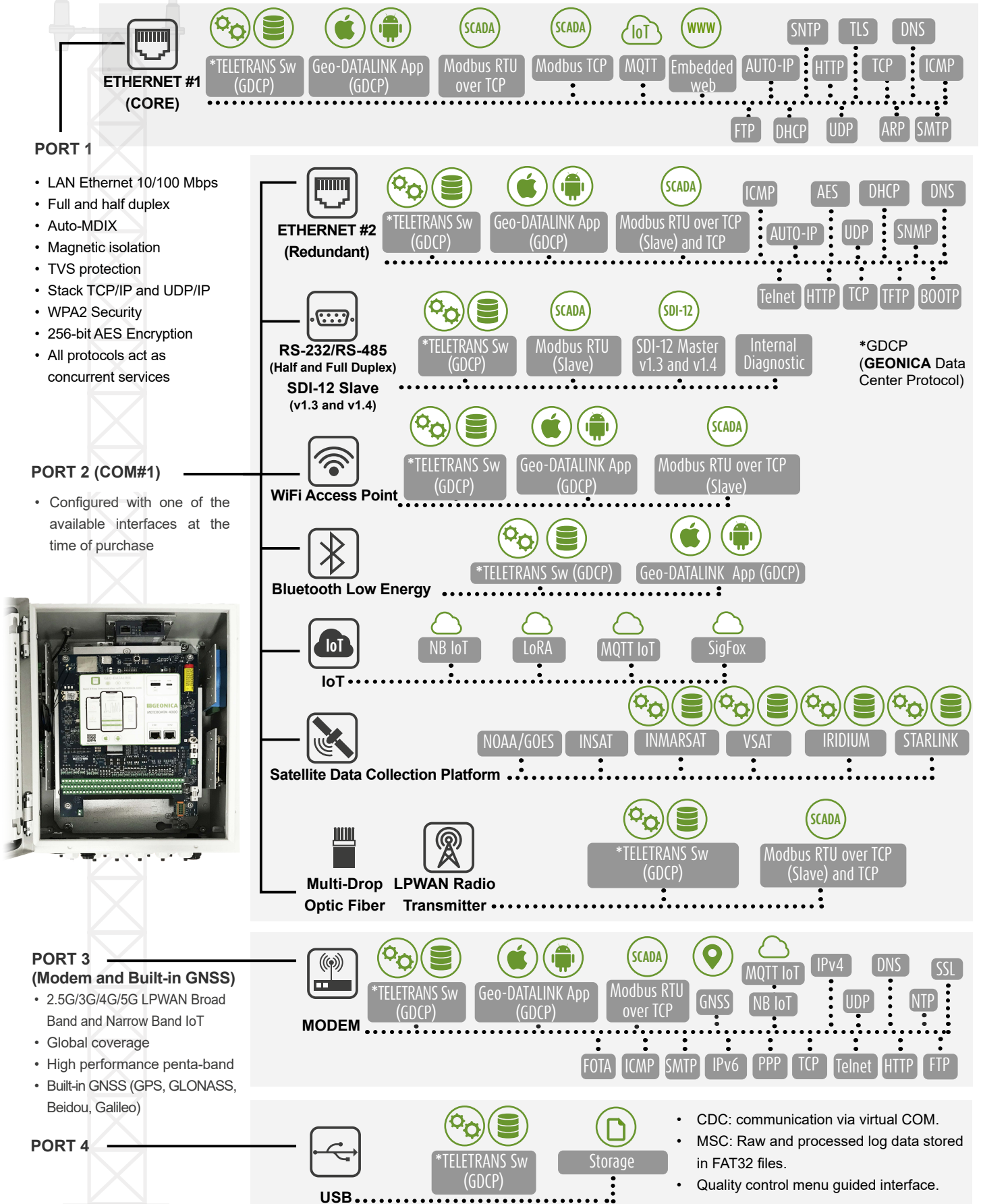

## SIGNAL ACQUISITION INPUTS FOR SENSORS

### 3 Serial Ports dedicated to communication buses for Smart Sensors

- Each port can be configured for specific interface / settings:
  - SDI12 v1.3&1.4 / RS232 / 422 / 485 (2/4-wires), half/full duplex
  - From 1.2 Kbps to 1 Mbps for RS232 or RS485, 7, 8 or 9 data bits, 1, 1.5 or 2 stop bits and no parity, even or odd parity.
- Selection of software-defined termination resistor.
- Selection of software-defined slew rate limits.
- Automatic activity detection in low power consumption mode.
- Ultra-fast data detection through interrupt triggering.
- Compatible with internal diagnostic log trace.
- Each of the 3 ports can be configured to collect data from multiple sensors sharing the same communication bus.
- Compatible with polled and non-polled protocols.
- Up to 4 sensors of different types / brands / models are supported by each port as long as the same protocol is used (up to 40 sps).
- In case of sensors of same type / brand / model with Modbus:
  - Up to 32 (1 variable) or 16 sensors (2 variables) for each port
  - Up to 1 sample per second for each sensor

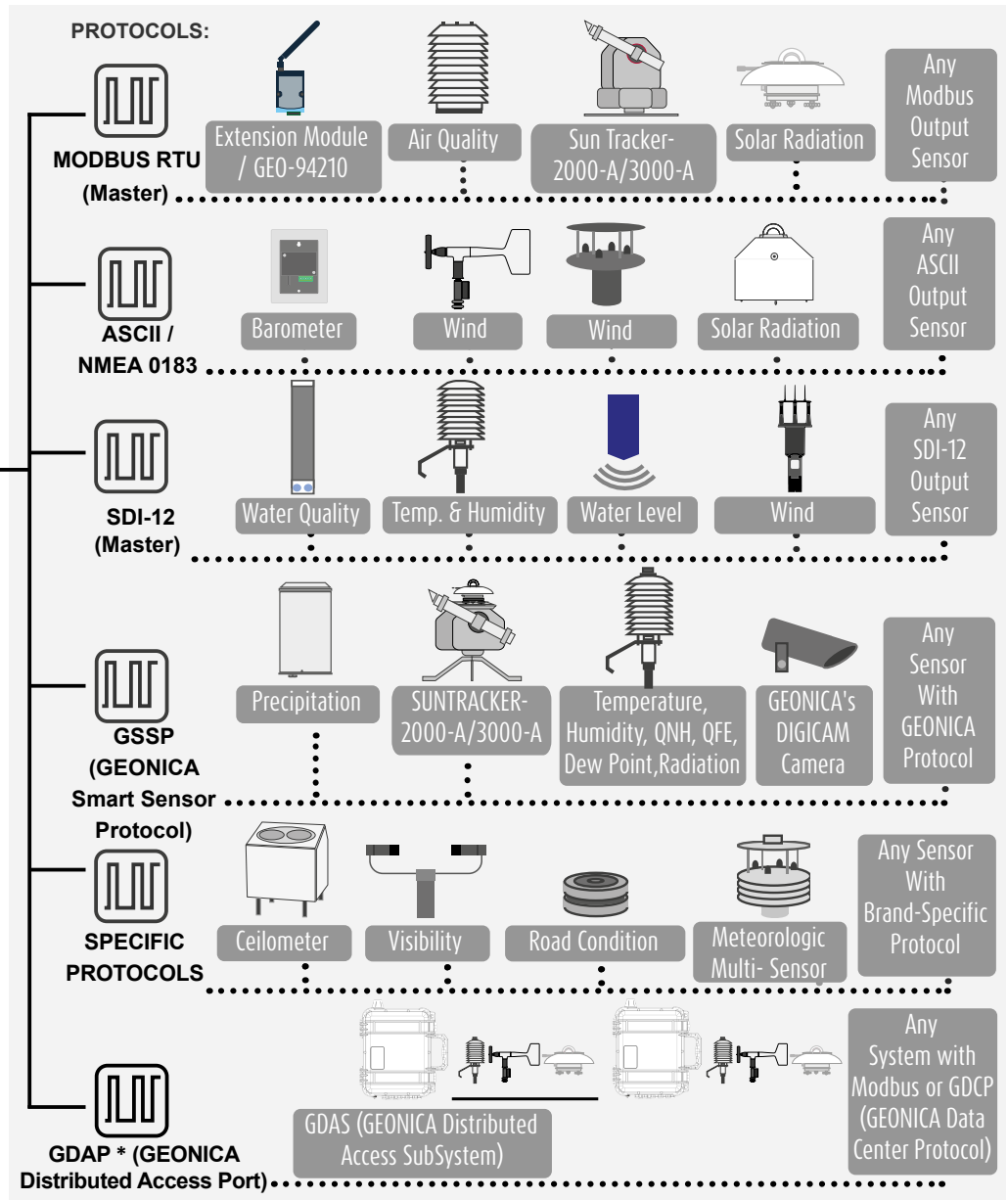
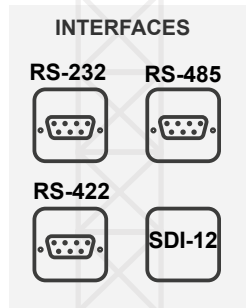

SMART SENSORS SERIAL PORT 1 (COM#2)

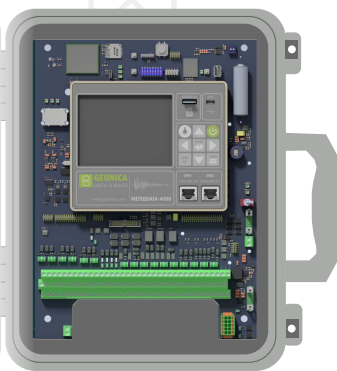

\* Tunnel mode to generate distributed smart architectures with various dataloggers or other devices

SMART SENSORS SERIAL PORT 2 (COM#3)

Stand-alone port with same configuration options as 'SMART SENSORS SERIAL PORT 1'

SMART SENSORS SERIAL PORT 3 (COM#4)

Stand-alone port with same configuration options as 'SMART SENSORS SERIAL PORTS 1 & 2'

## GEO-DATAVIEW SOFTWARE PACKAGE VERSIONS

The **GEO-DATAVIEW** software package is a set of applications for managing and displaying the data collected by the datalogger series **METEODATA-4000**. **GEONICA** provides different versions in order to cover the different clients needs. Each version includes specific services and applications.



	GEO-DATALINK Mobile App	WEBTRANS-4K Cloud Service	GEONICA M2M SIM Data Service	TELETRANS-W4K Desktop Software	WEBTRANS-4K Distributable Web Server

GEO-DATAVIEW BASIC	✓		Optional		
GEO-DATAVIEW ADVANCED	✓	✓			
GEO-DATAVIEW PREMIUM	✓	✓	✓		
GEO-DATAVIEW PRO	✓		Optional	✓	
GEO-DATAVIEW ENTERPRISE	✓		Optional	✓	✓



### GEO-DATALINK App

- TCP/IP (Modem, WiFi, Ethernet) and BLE (Bluetooth Low Energy) communication with each station.
- Instantaneous and log data displayed in graphs and tables.
- Internal diagnostics of the stations power supply lines, memories and communication interfaces.
- Data download (CSV) in the terminal and via FTP.
- Configuration of the station: calibration constants, storage periods, Modem and Ethernet communications, date, time, timezone, etc.
- 'Remote Access' mode: the station connects to **GEONICA** Cloud through the 3G/4G SmartPhone connection for technical assistance, system assessment, etc.

Parameter	Model	Type	Maker
Rain	DataRain	Meteorological	GEONICA
GEO-B1202L	GEO-PH1PE	GEO-GARAA	GEO-DARAA
GEO-AQUA	GEO-87H S	GEO-8R30 G	GEO-SR30 D
GEO-DR30 D	GEO-81102	GEO-05102	GEO-SR11 G
GEO-SR11 D	GEO-DR81	15189 PREC.	GEO-WIND S
S_4892_35	GEO-AGT426	GEO-INTERN	GEO-ADV IN
GEO-MEMO...	GEO-MODEM	GEO-BA3IC	GEO-THERM...

  

Sensor	Color	Function	METEODATA
1	Brown	RX	TXT-B3
2	Red	12VDC	+12VX
6	Blue	TX	RXR+3
7	Grey	GND	IGND
	Shield	Earth	EARTH



### TELETRANS-W4K Desktop Software

- Management for networks with a large number of stations.
- Automatic download of data from the stations into an SQL database.
- Automatic download of the station wiring diagram.
- Automatic download of the station Modbus memory map.
- Interactive station configuration: possibility of adding new sensors ('Drag and Drop') from an online sensor library. Any requested sensors will be added to this library within no more than 7 days.

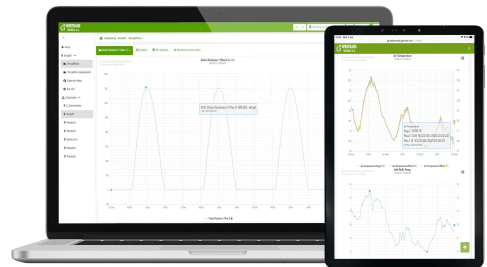

### WEBTRANS-4K Cloud Web Service

- Access through a Web platform to log data collected by station and stored in the cloud.
- Does not require any installation by the user.
- Web access protected by username and password.
- Multi-language interface (compatible with more than 70 languages)
- Displays stations on a map and real-time data in graphs.
- High-powered graphics that allow zooming, displaying maximums/ minimums/ averages and selecting the date range.
- Data download in CSV, TXT and Excel formats.
- Web Service API access to easily integrate the data collected by the stations series **METEODATA-4000** into third-party platforms or developments.



### Distributable Web Server WEBTRANS-4K

- Web platform that can be installed on Windows servers as a virtual machine.
- Own management of databases, stations and users.
- Customization of Web interface.
- The Web platform allows stations to be displayed on a map, access to log data to be displayed in graphs and exporting the data in CSV, TXT and Excel formats.

## IOT-BASED DATA COLLECTION PLATFORMS

- The **METEODATA-4000** format and transmission adapted to IoT protocols (through Narrow Band IoT, SigFox, LoRa, MQTT) facilitates the display of the data collected by the stations by means of specific software used for IoT data display and analysis.

## GENERAL TECHNICAL SPECIFICATIONS

### GENERAL SPECIFICATIONS

- **Main processor:** 32-bit ARM Cortex M4 Microcontroller optimized for low power consumption, with FPU, Multiply Accumulate Unit MAC (single cycle) and SIMD, running at 95 MHz (up to 150 MHz available).
- **Operating Temperature:** (Industrial range) -40°C to +85°C  
Extended range: -55°C to +85°C (optional, including certificate).
- **Memory and data storage:**
  - **Total onboard memory:**
    - System memory: 8MB SRAM + 8MB Flash NOR.
    - Data storage, settings and CPU drive FAT32: 8/16/32 GB Flash NAND.
  - **Removable redundant data storage backup (optional):**
    - Backup data storage and CPU drive FAT32: 8/16/32/64/128 GB µSD card (industrial temperature range).
    - Redundant log data and raw data backup.
    - Makes it possible to extract a copy of the data without having to wait for it to download.
- **Power Consumption:**
  - Idle mode (RTC and SRAM retention):  
41 µA @+12V: 0.5 mW
  - Active mode (32Hz scan + 3 active serial ports RS-232/RS-485)  
37.1 mA @+12V: 0.4 W
  - Ethernet #1 power requirements (Link + data exchange)  
Active mode + 39.2 mA @+12V: active mode +0.5W
- **Sample Period: 3.125 ms (32 channels @ 10Hz) to 1 day** (including data acquisition, processing, filtering, statistical calculation, logging and real time display/transmission).
- **RTC - TCXO Real Time Clock:**
  - Resolution: 1ms (combined RTC + SysClock).
  - Accuracy: ±1 min. per year (typ.)
  - Li-soc2 3.6V 2.6Ah (Saft LS14500) industrial grade lithium battery for RTC and SRAM for 6-year autonomy without external power supply.
  - Optional PPS GNNS correction ±10µs or ±20ms with NTP. Automatic selection of the best / more accurate clock source.
- **ARM RTOS (real-time operating system)** with application running in multitasking mode ('Pre-emptive Round Robin Multitasking').
- **HMI - Ultra Low Power Consumption Human Machine Interface (Optional):**
  - Memory-Display technology graphic LCD 4.4" QVGA with 120° viewing angle, backlight and independent physical keyboard mounted on the panel.
  - Multi-language interface for displaying instant and statistical data as numeric values and graphs, internal self-diagnostics of power supplies, communications and storage, date / time configuration, etc.
- **Brownout protection:** the integrity of user data is guaranteed during power supply failures through proprietary hardware and software algorithm that prevents data from being corrupted or lost.
- **Recalibration:** recommended every 6 years for units with certificate.
- **GNSS:** automatic correction of site position (< 3m 95%), date and time (with accuracy better than 0.1 s) by means of an integrated GNSS receiver with automatic time synchronization.
- **FOTA (Firmware Over The Air):** firmware automatic update to keep the system updated with most recently developed features.
- **High performance interconnection terminal block** for connecting sensors and other devices.

- **Compatible with eSIM M2M** for automatic switching of carriers based on QoS. This technology guarantees worldwide operation with a large number of operators using the same single SIM card and with optimized cost/bandwidth ratio for each geographic location.
- **Optional high performance embedded Linux expansion module:**
  - Enhanced 32-bit RISC CPU with variable cache, TCMS and MMU
  - 512 MBytes Flash, 128 MBytes SDRAM
  - Operating system: Linux Debian
  - Ethernet, MicroSD, 2xUSB and RS232 / RS485 interfaces

### ENCLOSURES & PHYSICAL FEATURES

#### METAL CABINET OPTION

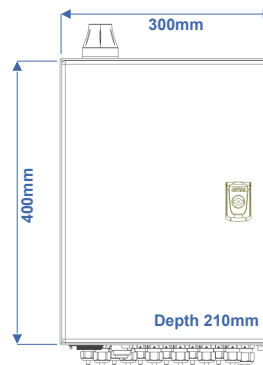

- Interior Volume: 29.95 dm<sup>3</sup>
- Material: AE metal cabinet
- Corrosion protection: UNE/EN ISO 12944 Class C3 (optional Class C4)
- Protection: NEMA 4, NEMA 4X, IP 66
- Up to 3 internal batteries (3 x 9Ah 12VDC).

#### PORTABLE CASE OPTION

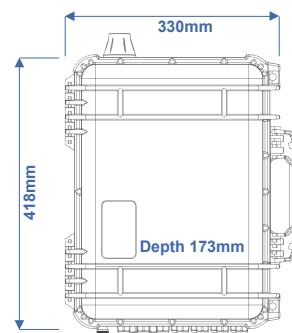

##### Standard Option

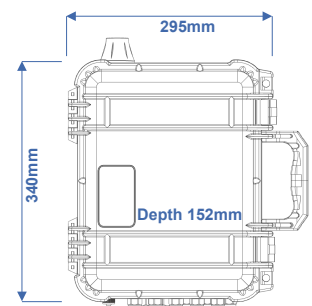

##### Compact Option

- Internal dimensions (standard option | compact option):  
372 x 260 x 155 mm | 300 x 225 x 132 mm
- Material: Polypropylene
- Floatability (standard option | compact option): 13.6 kg | 9.1 kg
- Protection: NEMA 6, NEMA 6P, IP67
- Certification: STANAG 4280- DEF STAN 81-41, MIL C-4150J
- Available for 3 (3 x 9Ah 12VDC) and 2 (2 x 9Ah 12VDC) included internal batteries, mounted internally.

### EMBEDDED DATA PROCESSING

- **Statistical processing** of instantaneous sensor data acquired by each of the datalogger's 32 measurement channels.
  - Up to 32 statistics can be configured for each channel: average, accumulated, integrated, maximum, minimum, standard deviation, logic OR function, WMO BuFR quality index, time of maximum and minimum value, moving average, etc.
  - Up to 2 configurable calculation periods for each statistic, from 1 minute to 24 hours.
- **Alarms.** Instantaneous data monitoring for the generation of real time alarms from a single channel or a combination of channels. Up to 32 alarm channels.
- **Algorithms and mathematical functions** programmed to perform internal calculations in accordance with WMO, ICAO, etc.
- **Internal calculation of variables included in the solar tracking algorithm.**

## ANALOG INPUTS

Up to 8 analog inputs for measuring differential voltage (DIF) / current / resistance / ratiometric  
 Up to 16 analog inputs measuring single-ended voltage (SE)

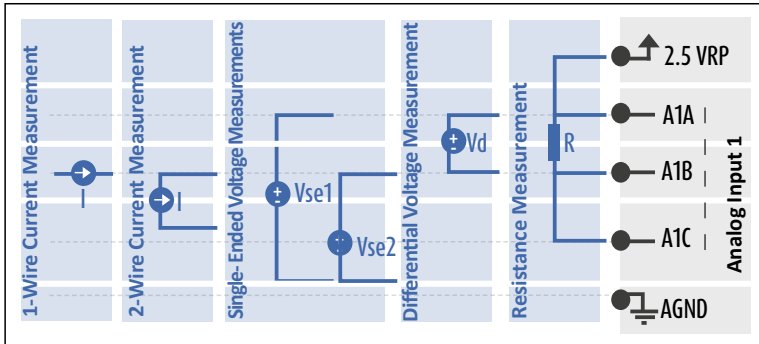

- **V, I, R and ratiometric measuring modes:** All the analog inputs are individually software configurable.
- **24-bit resolution.** Analog Front-End (AFE) delta-sigma.
- **Accuracy:** Configurable up to 25.1 bit ENOB
- **Configurable SNR** up to 142 dB
- **Sampling:**
  - 2 AD sigma-delta converters @ 1000 samples/sec each
  - Simultaneous sampling (paralleled conversions)
- **Terminals:** A1A/A1B/A1C - A8A/A8B/A8C

## VOLTAGE MEASUREMENT

- **No. inputs:**
  - Up to 8 Differentials (A1A/A1B - A8A/A8B)  
(1 high-range differential 0-30V. Terminals A1A/A1B)
  - Up to 16 Single-Ended (A1A-A8A and A1B-A8B)
- **Input impedance:**
  - >1 GOhm typ. @ 25°C, in high range
  - 80 MOhm typ. @ 25°C, in standard ranges
- **Input voltage limits:** ±5 V / Gain or Attenuation
- **Sustained voltage without damage:**
  - 10 V to +26 V, in high range
  - 0.3 V to +5.3 V, in standard range
- **Common mode rejection ratio:** 110 dB (typ.)
- **DC power rejection:** 100 dB (typ.)
- **First notch frequency range:** 2.5 Hz to 30 KHz
- **Accuracy:**
  - ±0.02% from 0 to +40°C K=1
  - ±0.03% from -40 to +85°C K=1
- **Voltage measurement offset:** automatically removed by self-calibration.
- **Ranges and resolutions:** for voltage measurements, these are the same for differential and single-ended mode measurements.

## CURRENT-LOOP MEASUREMENT

The current-loop measurements are made by a half-bridge connection using a high-accuracy reference resistor.

- **No. inputs:** Up to 8 simultaneous inputs (A1B/A1C - A8B/A8C)
- **Maximum input voltage:** ±5 V
- **Resistance to ground:** 100 Ohm
- **Current measurement shunt resistance:** 100 Ohm (10 Ohm optional)
- **Maximum current measurement range:** (additional ranges optional)
  - ±50 mA, in high range
  - ±30 mA, in standard range
- **Absolute maximum current:** ±50 mA (up to ±300 mA optional)
- **Accuracy:**
  - ±0.02% from 0 to +40°C K=1
  - ±0.03% from -40 to +85°C K=1

## RESISTANCE MEASUREMENT

The resistance measurements are taken using an excitation voltage and an internal high-accuracy reference resistor.

- **No. inputs:** Up to 8 simultaneous inputs (A1A/A1B/A1C - A8A/A8B/A8C)
- **Measurement bridge circuits:** 2, 4 and 6 wires
- **Accuracy:**
  - ±0.02% from 0 to +40°C K=1
  - ±0.03% from -40 to +85°C K=1

## ANALOG RANGE AND RESOLUTION

	RANGE	fN = 1000 Hz		fN = 100 Hz (By default)		fN = 50/60 Hz		fN = 5 Hz	
		Bits (RMS)	Resolution (RMS)	Bits (RMS)	Resolution (RMS)	Bits (RMS)	Resolution (RMS)	Bits (RMS)	Resolution (RMS)
VOLTAGE MEASUREMENT	-10 V a +26 V High Range	21.7	23.48 µV	23.4	7.23 µV	23.9	5.11 µV	25.0	2.38 µV
	-10 V a +20 V High Range	21.3	15.49 µV	23.0	4.77 µV	23.6	3.15 µV	24.8	1.37 µV
	±10 V High Range	21.3	7.75 µV	23.0	2.38 µV	23.6	1.57 µV	24.8	0.69 µV
	±5 V High Range	21.3	3.87 µV	23.0	1.19 µV	23.6	0.79 µV	24.8	0.34 µV
	±5 V Low Impedance	21.8	2.74 µV	23.5	0.84 µV	23.9	0.64 µV	25.1	0.28 µV
	±3 V	21.7	2.94 µV	23.4	0.90 µV	23.9	0.64 µV	25.0	0.30 µV
	±2.5 V	21.3	1.94 µV	23.0	0.60 µV	23.6	0.39 µV	24.8	0.17 µV
	±1.25 V	20.8	1.37 µV	22.5	0.42 µV	23.0	0.30 µV	24.5	0.11 µV
	±625 mV	20.2	1.04 µV	22.0	0.30 µV	22.5	0.21 µV	24.0	0.08 µV
	±312.5 mV	19.8	0.69 µV	21.4	0.23 µV	21.8	0.17 µV	23.3	0.06 µV
±156.25 mV	19.2	0.52 µV	20.8	0.17 µV	21.1	0.14 µV	22.7	0.05 µV	
±78.125 mV	18.3	0.48 µV	19.8	0.17 µV	20.3	0.12 µV	21.8	0.04 µV	
CURRENT MEASUREMENT	±300 mA (Opt. RS 10 Ohm)	21.7	293.53 nA	23.4	90.34 nA	23.9	63.88 nA	25.0	29.80 nA
	±30 mA	21.7	29.35 nA	23.4	9.03 nA	23.9	6.39 nA	25.0	2.98 nA
	±25 mA	21.3	19.37 nA	23.0	5.96 nA	23.6	3.93 nA	24.8	1.71 nA
	±12.5 mA	20.8	13.69 nA	22.5	4.21 nA	23.0	2.98 nA	24.5	1.05 nA
	±6.25 mA	20.2	10.38 nA	22.0	2.98 nA	22.5	2.11 nA	24.0	0.75 nA
	±3.125 mA	19.8	6.85 nA	21.4	2.26 nA	21.8	1.71 nA	23.3	0.61 nA
	±1.563 mA	19.2	5.19 nA	20.8	1.71 nA	21.1	1.39 nA	22.7	0.46 nA
±0.781 mA	18.3	4.84 nA	19.8	1.71 nA	20.3	1.21 nA	21.8	0.43 nA	
RESISTANCE MEASUREMENT	From 25 Ohm to 10 KOhm	Reference resistance for measurement: 1 KOhm 0.01% ± 5ppm/°C							
	From 10 KOhm to 10 MOhm	Reference resistance for measurement: 100KOhm 0.05% ± 5ppm/°C							

## DEDICATED PULSE MEASUREMENT COUNTERS

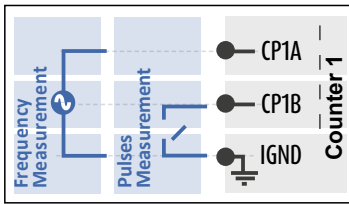

- 1 Low power consumption counter (32 bits with 16-bit prescaler).
- **Up to 4 Counters** (32 bits with 7-bit prescaler).
- **CP1-CP4 individually configured for Type A/Type B.**
- **CP5 for high-frequency.**

- **Measurements:** pulse width or period, frequency and pulse totalizer.
- **Input signal types:**
  - Impulsive:  $\pm 15$  Vpp maximum
  - Frequency: Sinusoidal, TTL/CMOS 5V/3.3V
  - Contact closure: reed-relay
- **Terminals** (depending on the frequency of the input signal):

	TYPE A	TYPE B	HIGH FREQUENCY
<b>Terminals</b>	CP1A - CP4A	CP1B - CP4B	CP5A
<b>Max. Frequency</b>	150 Hz	4 KHz	250 KHz

- **Maximum input voltage:**  $\pm 30$  V
- **Input sensitivity:**
  - TTL/CMOS\_5V/CMOS\_3.3V/2.3 Vdc with input hysteresis of 100 mVpp
  - Contact closure input: 5 mA to 10 mA
  - High event detection:  $> 2$  V
- **Pull-up resistance:** 50 KOhm to 3.3 V
- **Input resistance:** 1 KOhm
- **Counters are active in low power consumption mode**
- **Glitch filter and edge detection** (up /down)

## DEDICATED DIGITAL INPUT AND OUTPUT PORTS

Up to 2 non-isolated TTL/CMOS input ports.

Up to 2 isolated 'PHOTOMOS' input ports & up to 4 isolated 'PHOTOMOS' output ports.

- Automatic activity detection in low power consumption mode.
- Software configurable input glitch filter.
- Compatible with: ON/OFF status, edge detection, quadrature input, pulse-width modulation.

	TTL / CMOS PORTS	'PHOTOMOS' PORTS
<b>Terminals</b>	ED3 and ED4	ED1A/ED1B & ED2A/ED2B SD1A/SD1B - SD4A/SD4B
<b>Output Signal</b>	CMOS 5V	Voltage-free contact
<b>Input Signal</b>	Impulse 15Vpp max.	Contact closure
<b>Operation</b>	Input sensitivity: CMOS 3.3V, (5V tolerant) 2.3 Vdc with input hysteresis of 100 mVpp.	<ul style="list-style-type: none"> <li>• Opto-isolated, up to 4000 Vrms</li> <li>• Switching current/voltage (AC/DC): <ul style="list-style-type: none"> <li>• <math>\pm 4</math> A / <math>\pm 20</math> V</li> <li>• <math>\pm 2.5</math> A / <math>\pm 60</math> V</li> <li>• <math>\pm 0.240</math> A / <math>\pm 400</math> V</li> </ul> </li> <li>• Direct and inverted operating modes</li> </ul>

## POWER SUPPLY

### POWER SUPPLY INPUTS

+12VDC (10.8VDC – 15VDC) with reverse voltage protection, overcurrent protection and voltage detection / measurement.

### EXTERNAL POWER SUPPLY INPUTS

(Connection to elements outside the enclosure)

- **Connection to External Battery 60Ah 12VDC (10.8VDC - 15VDC)**
- **Charger #1 and Charger #2 with connection to:**
  - Solar panel (10VDC - 24VDC)
  - Power grid voltage: 100 to 240 VAC

- MPPTS integrated chargers for internal batteries and external 60Ah battery.
- 28V sustained voltage limit without damage.
- Input current limit (max. charge capacity): 6.6 A (-40 to +85°C)
- Charger #1' and 'Charger #2' inputs can operate concurrently and redundantly.
- For the connection to the power grid, a power supply (PS) unit is included:
  - Optimized to minimize power consumption.
  - 3SU design, 52.5mm wide, 85 ~264VAC universal input.
  - Class II isolation
  - Protections: short-circuits, overcurrent, overvoltage.
- Direct connection to vehicle power plug with no additional charger/regulator.

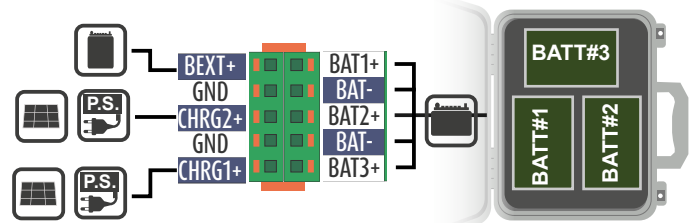

### INTERNAL POWER SUPPLY INPUTS

(Up to 3 redundant internal batteries)

Internal Batteries (3 redundant)

- SLA, GEL/AGM 3 x 9 Ah (12 V) or LiFePO<sub>4</sub> 3 x 12 Ah (12 V)
- Independent batteries with redundant power supply system.
- Charging of internal batteries via a solar panel and/or redundant and concurrent power grid connection.
- Low-battery detection with hysteresis mode shutdown to increase the service life of the battery.

### OUTPUT POWER SUPPLY (VOLTAGE EXCITATION)

Up to 12 power supply outputs for sensors, accessories and other devices:

- Total power output limit of 6.6A (-40 to +85°C) with ACOV, UVLO, Cycle-by-Cycle Charge Overcurrent Protection & Thermal Shutdown protections.
- The 12 outputs are internally managed by the micro-controller through 4 independent activation profiles that enable optimization of the total power consumption of the system, turning off the connected components/sensors while they are not being used.

TERMINALS	PROFILE MODE	VOLTAGE	CURRENT LIMIT	TEMPERATURE
+12VX	Permanent	12V	3500 mA (total the 4 lines)	-40 to +85°C
12VC1 /12VC2/12VC3	Switched			
5VP	Permanent	5V	1000 mA (total the 4 lines)	-40 to +85°C
5VC1 / 5VC2 / 5VC3	Switched			
VRP	Permanent	2.5V	50 mA (total the 4 lines)	-40 to +85°C
VRC1 / VRC2 / VRC3	Switched			

## TERMINALS, ELECTROSTATIC PROTECTION AND ACCESSORIES

- Sensors and accessories must be connected to the **METEODATA-4000** series through the high performance terminal block (up to 15A per contact and 400V rated voltage), compatible with 2.5 mm<sup>2</sup> cable. Wiring panel temperature can be measured using an optional 44031RC Precision Epoxy NTC Thermistor, located among the three rows of analog input terminals.
- Teletrans software allows any sensor to be integrated into the datalogger simply by dragging an icon from an on-line sensor library ('Drag and Drop'). This software also manages the available hardware resources of the datalogger and automatically generates an updated wiring schematic with the instructions to connect new sensors.

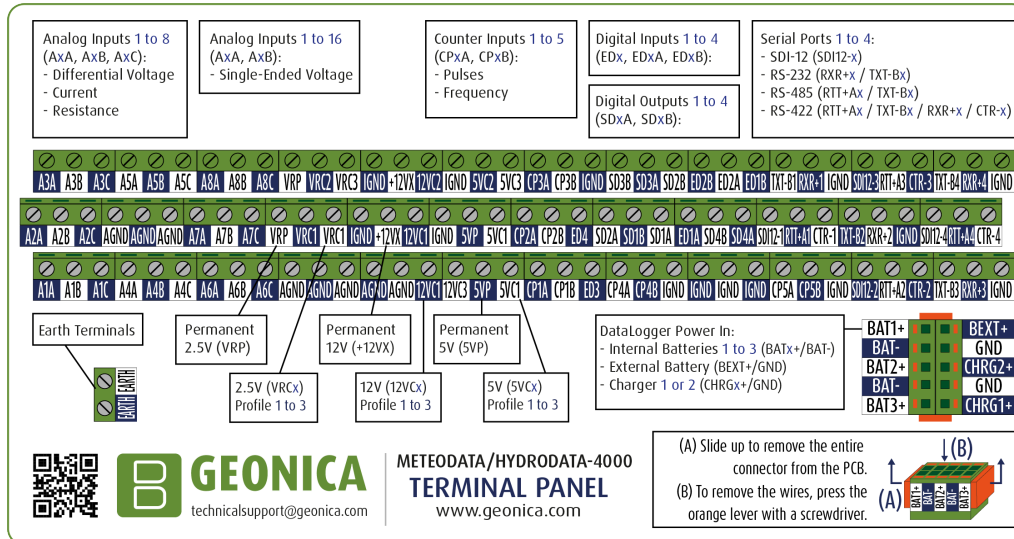

### EMI / ESD / SURGE PROTECTION

- Cabinet**
  - Faraday cage
  - IP66 / IP67
- EMI Filtering**
  - Block type filter on power supply interfaces
  - LC PI filter in digital interfaces
  - RC filter on analog interfaces (common and differential modes)
- ESD and SURGE Protection**
  - 20KA 8/20us (Class 2) GDT + 1W overload protection series resistor + TVS 600W 10/1000us diode (Class 1) on non-power lines.
  - Power supply input protected against overvoltage, over-current and reverse polarity through a combined solution of 500A 8/20us varistor (Class 2) + fuse in power lines, etc.

### MULTIPURPOSE INTERFACE EXTENSION MODULES

- Easily configurable ('Drag and Drop') and simple installation.
- Each **METEODATA-4000** series datalogger allows the integration of various extension devices of the same or different types.
  - Hardware interface extension modules: analog inputs, counters, digital inputs/outputs, etc.
  - Protocol-extension modules: NTCIP, DGT, etc.
  - Extension of sensors connected up to 5 Km by LPWAN radio-link.
  - Modules for additional communication interfaces.
- See doc. '9722.0103'.

## STANDARD COMPLIANCE SPECIFICATIONS

- WMO - World Meteorological Organization:**
  - No. 8 Guide to Meteorological Instruments and Methods
  - Guidelines on Quality Control Procedures for Data from AWS
- ICAO - International Civil Aviation Organization**
  - 9837 Manual on Automatic Meteorological Observing Systems at Aerodromes
- Roads:**
  - (DGT) UNE 135441-2, (NTCIP) NTCIP 1204 V03
- Nuclear Facilities:**
  - ANSI/ANS 3.11-2015 Determining Meteorological Information at Nuclear Facilities
- Solar Plants:**
  - UNE/EN 61724-1 Photovoltaic system performance: Monitoring
  - ISO 9060 Solar Energy Specification and Classification of Instruments
- Air Quality:**
  - ANSI/UL 2075 Standard for Gas and Vapor Detectors
- Automatic Weather Stations Networks**
  - (Datalogger) UNE-500540
  - (System) UNE-500510, 500520, 500530, 500550
- EMC:** Emissions: CISPR22 Class B / EN-55022
- EMC:** Electromagnetic immunity:
  - IEC 61000-4-2 ESD immunity
  - IEC 61000-4-3 RF immunity
  - IEC 61000-4-4 EFT immunity
  - IEC 61000-4-5 Surge immunity
  - IEC 61000-4-6 Immunity to induced disturbances
- Surge classification:** IEC 61643-11 Class 1 and Class 2
- Ingress protection rating:** IP66/IP67, NEMA 4/4X
- Safety:** EN IEC 62368-1
- European Directives EU:**
  - Low Voltage: 2014/35/EU
  - EMC: 2014/30/EU
  - RoHS: 2011/65/EU

