

Model GEO-StacSense

Water Quality UV Spectral Sensor

UV Optical Technology for optimal measurements

- UV 254 spectral absorption without any reagents or consumables
- Multi-parameter measurement: SAC₂₅₄, CODEq, TOCe_q & BODEq, Turbidity eq
- Modbus RS-485 digital communication
- Automatic Turbidity compensation



GEO-StacSense

Water Quality UV Spectral Sensor



METEODATA / HYDRODATA

Datalogger with integrated comms
(3G / GPRS, Line, Radio or Satellite)

Scope

- Urban wastewater treatment: detecting organic load variations during input / treatment process / output.
- Treatment of industrial effluents
- Surface water monitoring
- Fish farming, aquaculture (freshwater)
- Drinking water: monitoring Organic matter in raw water, oxidation process, coagulation, activated carbon filtration.

The Spectral Absorption Coefficient (SAC) at 254 nm helps determine the Organic Content of a water sample but also the COD, TOC and BOD parameters by applying the appropriate correlation coefficients.

Measurement principle

The StacSense probe uses UV absorption at 254 nm to measure organic compounds dissolved in water. This absorbance is correlated with the concentration of TOC, COD and BOD to provide a high-performance probe requiring no consumables.

A reference measurement at 530 nm is used to compensate for the presence of particles in the sample that also absorb UV light and to establish the Turbidity parameter.

The use of a state-of-the-art high-performance UV LED, combined with rigorous ignition management, offers an optimal variance of the signal.

Digital Communication

The GEO-StacSense sensor connects directly to **METEODATA / HYDRODATA** datalogger or other equipment using Modbus RS-485.

Interference-proofing: pre-amplification built into the sensor and digital signal processing.

All calibration, history, user and measurement data are processed directly in the GEO-StacSense Probe and transmitted by Modbus RS-485 or SDI-12.

Technical Features

Measurements	
Measurement principle	UV 254 nm absorption
Compensation	Turbidity at 530 nm Internal temperature
Wave lengths	254 nm (turbidity correction at 530 nm)
Type of detector	Silicon Photodiode
Light sources	LED UV 254 +/- 5nm and 530 +/- 5 nm
Optical paths	2 and 50 mm
Measurement frequency	Maximum 1 measurement / 2s
Ingress Protection rating	IP68
Max. immersion depth	50 meters
Maximum pressure	5 bars
Operating temperature	0 - 40°C
Storage temperature	-10°C to +50°C
pH range	pH2 to.pH12
Dimensions (D x L) (mm)	48x371 or 48x419 (see overall dimensions diagram)
Weight	1600 - 1800g depending on the optical path (cable not included)
Equipment	Body: Stainless steel 316 (1.4401) Optical windows: Quartz (Corning 7980) Cable: Bare wire with polyurethane sheath Seals: Fluoroelastomer (FPM/FKM)
Cable	9 shielded conductors in 3, 7 and 15m. <i>Other lengths on request</i>
Signal interface	Modbus ¹ RTU (RS-485) / SDI12 ² (TTL) ¹ Sensor mute in Modbus for 2s at the most between the measurement request and the option to read the status or measurements ² Framework of measurement results in SDI12 after a maximum of 2s instead of the 850 ms standard maximum ^{1,2} The sensor responds in Modbus / SDI12 including when on Standby
Sensor power supply	5.4 V ^{1,2} at 26 V ³ DC ¹ Absolute minimum 5.2 V with 1 m of cable ² Minimum voltage subject to cable length-related losses ³ 28.0 V absolute maximum
Typical consumption at 5.4 V	Automatic standby less than 10 µA (54 µW) Maximum peak current: 600 mA (2 ms) Maximum current during the measurement: 100 mA (540 mW) Average current during the measurement: 70 mA (378 mW) Average current (1 measurement / 2s): 35 mA (189 mW) Energy for 1 measurement (1.5 s): 158 µWh
Typical consumption at 12 V	Automatic standby less than 10 µA (120 µW) Maximum peak current: 400 mA (1.5 ms) Maximum current during the measurement: 70 mA (840 mW) Average current during the measurement: 60 mA (720 mW) Average current (1 measurement / 2s): 30 mA (360 mW) Energy for 1 measurement (1.5 s): 300 µWh
Typical consumption at 24 V	Automatic standby less than 10 µA (240 µW) Maximum peak current: 300 mA (1 ms) Maximum current during the measurement: 65 mA (1560 mW) Average current during the measurement: 50 mA (1200 mW) Average current (1 measurement / 2s): 25 mA (600 mW) Energy for 1 measurement (1.5 s): 500 µWh
EMC compliance	NF EN 61326-1: 2013-05 RS-485 Modbus RTU & SDI12 ¹ The sensor is qualified for standard use with a dedicated cable including power supply and communication lines specific to the sensor network. ² When connected to a DC power supply network separated from the RS485 communication lines; additional shielding must be used on the system to protect the sensors from shock waves from an impact.

Measurement Ranges – Optical Path

Op.T	Parameters	Measurement range *	Units	Detection limit	Quantification limit	Accuracy **	Application
2 mm	SAC ₂₅₄	0-750	Abs/m	1.7	5	1 or +/-3%	Wastewater
	COD _{eq}	0-1300	mg/L	3	9	2 or +/-3%	
	BOD _{eq}	0-350	mg/L	1	3	1 or +/-3%	
	TOC _{eq}	0-500	mg/L	1.5	4	1 or +/-3%	
	Turbidity eq	0-500	FAU	1.5	5	5 or +/-5%	
50 mm	SAC ₂₅₄	0-30	Abs/m	0.20	0.3	0.1 or +/-3%	Drinking Water
	COD _{eq}	0-50	mg/L	0.15	0.6	0.2 or +/-3%	
	BOD _{eq}	0-15	mg/L	0.10	0.2	0.1 or +/-3%	
	TOC _{eq}	0-20	mg/L	0.10	0.2	0.1 or +/-3%	
	Turbidity eq	0-40	FAU	0.40	1.2	1.0 or +/-7%	

Performance levels obtained under laboratory conditions (controlled temperature and stirring, aqueous solutions of KHP)

* Optical path 2 and 50mm, Linearity: > 0.99 on the given range.

** Highest value

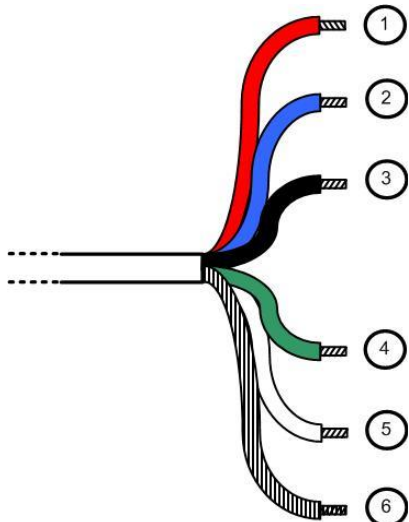
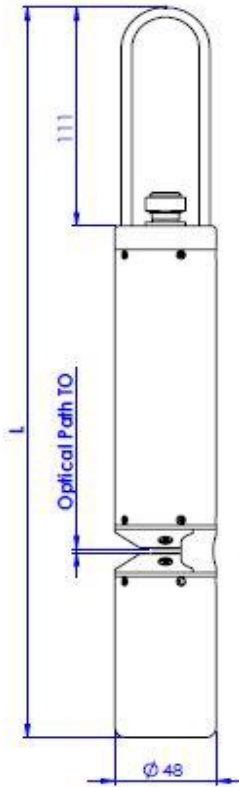
Electrical connections		Mechanical Perspective																		
	<p>Cable length from 15 to 100 m</p>	<p>RED YELLOW ORANGE PURPLE PINK</p> <p>Power Supply, V+</p>																		
				<p>2 - Blue SDI-12</p> <p>3 - Black Weight</p> <p>4 - Green B "RS-485"</p> <p>5 - White A "RS-485"</p> <p>6 - Green/yellow Cable shielding</p>																
<p>Cable length up to 15m</p>	<p>Connect wires 3 and 6 together</p>																			
<table border="1"> <tr><td>1 - Red</td><td>Power Supply, V+</td></tr> <tr><td>2 - Blue</td><td>SDI-12</td></tr> <tr><td>3 - Black</td><td>Weight</td></tr> <tr><td>4 - Green</td><td>B "RS-485"</td></tr> <tr><td>5 - White</td><td>A "RS-485"</td></tr> <tr><td>6 - Green/yellow</td><td>Cable shielding</td></tr> </table>	1 - Red	Power Supply, V+	2 - Blue	SDI-12	3 - Black	Weight	4 - Green	B "RS-485"	5 - White	A "RS-485"	6 - Green/yellow	Cable shielding	<p>Connect wires 3 and 6 together</p>	<table border="1"> <tr> <th>Optical Path TO</th> <th>Overall length L</th> </tr> <tr> <td>2 mm</td> <td>371 mm</td> </tr> <tr> <td>50 mm</td> <td>419 mm</td> </tr> </table>	Optical Path TO	Overall length L	2 mm	371 mm	50 mm	419 mm
1 - Red	Power Supply, V+																			
2 - Blue	SDI-12																			
3 - Black	Weight																			
4 - Green	B "RS-485"																			
5 - White	A "RS-485"																			
6 - Green/yellow	Cable shielding																			
Optical Path TO	Overall length L																			
2 mm	371 mm																			
50 mm	419 mm																			